

# NEDELKO

YOUR  
TECHNICAL  
SPECIALIST.

## SAFETY SOLUTIONS FOR YOUR WORKPLACE



# SAFETY FIRST

Industrial safety showers are essential safety devices in industries that deal with hazardous materials and chemicals. These devices provide immediate relief to workers exposed to hazardous substances or avoid (permanent) injury to the skin or eyes. They are required by law in many industries.

Nedelko is a specialist in the field of safety showers. The products stand out due to their ease of use, durability, and reliability. All the safety showers meet the DIN and ANSI standards.



## TEMPERATURE CONTROLLED SHOWERS (EX)

- Heated shower by means of a boiler connected to facility water
- Safe solution for indoor and outdoor use
- Suitable for operation in normal areas and hazardous zones 1&2



## TANK SAFETY SHOWER (EX)

- Heated shower by means of heating element in a tank
- Can be used in mobile situations or as standalone
- Suitable for operation in normal areas and hazardous zones 1&2
- Legionella control through an additive

## EYE / FACE WASH UNITS (EX)

- Extremely durable with collection tray and cover
- Due to the shape easy to find and use in case of emergency
- Can be applied to a safety shower or standalone use
- Suitable for operation in normal areas and hazardous zones 1&2



## RENT TANK SHOWER (EX)

- When a temporarily solution at short term has to be provided
- For use during shutdowns or turnarounds
- Easy to transport with a forklift truck



# ENSURE SAFE MOVEMENT

Nedelko offers a range of products specifically designed to ensure safe movement on industrial plants.

Looking for an industrial work platform, safety stairs or crossover?

Then you have come to the right place at Nedelko. With the separate components of ErectaStep, any application can be assembled.

Combine your modular platform stairs with YellowGate safety gates and ensure that employees can work safely. Additionally, Nedelko provides a range of anti-slip products that are standardized or customized to meet strict safety standards, ensuring the prevention of accidents caused by slippery floors due to moisture, chemicals, or grease.

## STAIRS & WORK PLATFORMS

- 3D design configuration (on site) according to your needs
- After approval drawings and datasheets can be provided
- The whole structure is built up from only 5 basic modules
- Lower costs because of the use of modular system
- No welding or fabrication required because of a quick bolt-together assembly
- Safety compliant (OSHA)

TAILORED  
TO YOUR  
NEEDS IN 3D

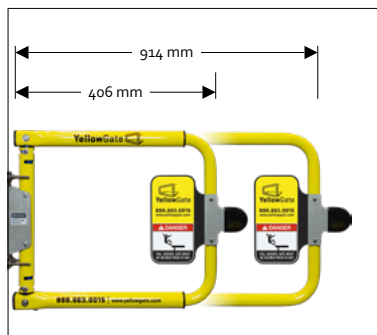
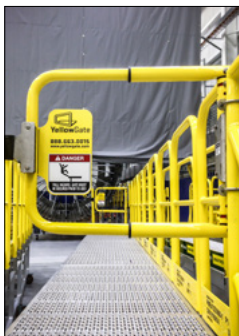
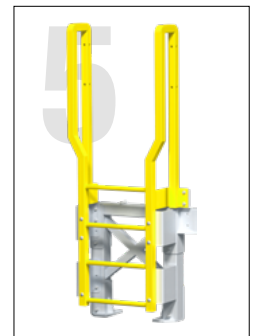
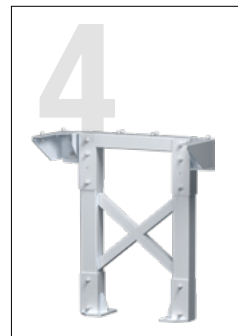

## SAFETY GATE

- Universal safety gate to be used for numerous applications
- With universal mounting kit
- OSHA compliant

No more measuring, just order directly.

## ANTI-SLIP PRODUCTS

Most durable and versatile anti-slip solutions

- Comply with the most stringent floor safety standards
- Effective in wet and oily conditions
- Non-conductive – eliminates electrical hazards

TAILORED  
TO YOUR  
NEEDS

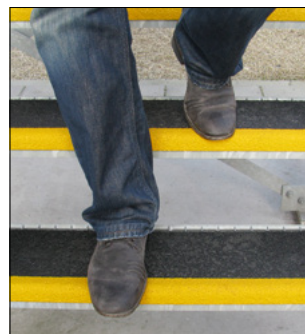



# SAFE MAINTENANCE

Accidents can be prevented thanks to our complete Lockout/Tagout solutions. Every year, thousands of workers are injured, fatal or otherwise, during repair and maintenance work on installations, industrial power sources and machines. Many of these accidents are caused by insufficient locking of the energy supply. Lockout Tagout is the way to prevent energy from being released in an unexpected way. Save valuable downtime and keep your employees safe with Nedelko's wide range of Lockout/Tagout devices.

## MECHANICAL LOTOTO

### CABLE LOCK FOR GATE VALVES

- Universal cable lock for ball, butterfly and hand wheel valves and other types of valves
- Durable and resistant to chemicals and corrosion



### BLIND FLANGE LOCKOUT

- Best practice pipeline maintenance solution
- Ensures the blind will not unintentionally be removed until all work is complete
- Small, medium and large version available
- Durable aluminum and hardened steel construction withstands conditions indoors and out



### ROTATING GATE VALVE LOCKOUTS

- Surrounds the valve operating handle to protect against accidental valve opening
- Durable and resistant to chemicals and corrosion
- Multiple workers can apply their lockout hasps or personal safety locks



## TAGS

- Standard and customized
- Made of durable flexible polyester
- Resistant to weather influences



## ELECTRICAL LOTOTO

### LOW VOLTAGE NV FUSE RAILS

- With symbols: Do Not Switch and Warning Electricity



### MINIATURE BREAKER LOCKOUT

To prevent accidents and injury when multiple people work with energy. Lockout easier than ever.

- Tool free and universal
- Padlock can be applied horizontally or vertically
- Can be mounted side-by-side on adjacent miniature circuit breakers
- Durable thermoplastic material is chemical resistant and performs effectively in extreme environments



### ROUND / BOTTLE FUSE HOLDER LOCKOUT

- Prevents incorrect use
- Industrial isolation plugs DII and DIII
- Striking red
- Made of ABS, PC & steel / brass components



## SHADOW BOARDS

- Perfect tool to manage your lock park
- Clear and efficient storage systems for your LOTOTO products and documents
- Made of durable materials
- Personalization with your logo and/or other info



# SAFETY SIGNS

Show the contents of your pipes. Unidentified or insufficiently identified pipelines certainly pose a real danger. Proper labeling of pipes and equipment helps prevent accidents by quickly identifying hazards, fluid type, and flow direction. As an employer you are obliged to identify pipes in accordance with European Directive 92/58. This guideline is ratified in the Netherlands by Royal Decree 530 'Safety and health signage'. Safety signs provide critical information on handling hazardous materials and warning of potential dangers, promoting safety awareness and a safer work environment. Nedelko pipe markers and safety signs are durable and resistant to extreme weather conditions and chemicals.

## PIPE MARKING

- Standard stickers and custom made
- Standard or in roll form
- UV and scratch resistant and resistant to extreme weather conditions and chemicals
- Compliant with ISO 20560



STANDARD

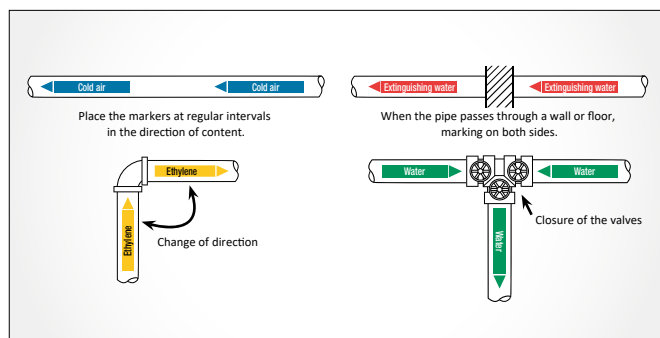

ROLL FORM

## SAFETY SIGNS

- From inventory to installation – turnkey solution
- Solutions in accordance with HACCP
- Standard and custom made
- Customization possible with company logo or a collection of icons



## DIY SIGNING - PRINTERS & SOFTWARE

Print site and security identification yourself, with one of our signage printers. The different sign and label printers offer possibilities to print labels quickly and efficiently, so that you can prevent unsafe or unclear situations. Create your own design using the software. Depending on the printer, you can print the label in one or more colors and even cut it out. This includes pipe coding, safety signage, signage, tags, CLP/GHS labels, and general labelling.

- Multicolor printing
- Die-cut shape
- Easy label creation
- Print on variety of material options

# NEDELKO

## YOUR TECHNICAL SPECIALIST.

2023-03 - v1.0

## NEDELKO SAFETY SOLUTIONS

A safe industrial workplace is crucial for the well-being of employees and the success of businesses. Nedelko offers full range solutions to reduce accidents in the workplace and create a safer work environment.

For over 65 years Nedelko is your trusted partner and supplier of electrotechnical materials, (intelligent) LED lighting and energy- and safety solutions. With more than 100 employees and establishments in The Netherlands, Belgium, Czech Republic and Germany, we supply the European (electro)technical market of the best products. Fast and full of commitment! Our headquarters and distribution center are settled in Barendrecht, The Netherlands.

Our true strength is not only set in a large assortment and fast delivery. Personal contact and building of sustainable relationships are just as important.

Our safety specialists provide customized solutions with highly qualified brands:



HIGH QUALITY



SPECIALIST  
KNOWLEDGE



COMPLIANT  
STANDARDS



CUSTOMIZATION



LOURENS BEZEMER  
SAFETY SPECIALIST

### HEAD OFFICE

#### NEDELKO B.V.

Riga 10  
2993 LW Barendrecht  
T +31 (0)180 64 54 00  
E [info@nedelko.nl](mailto:info@nedelko.nl)  
W [www.nedelko.nl](http://www.nedelko.nl)

### OFFICES

#### NEDELKO BELGIUM N.V.

Prins Boudewijnlaan 49  
2650 Edegem  
T +32 (0)3 826 99 99  
E [info@nedelko.be](mailto:info@nedelko.be)  
W [www.nedelko.be](http://www.nedelko.be)

#### NEDELKO S.R.O.

Ke Slivenci 48  
154 00 Praha 5 - Lochkov  
T +420 222 563 003  
E [info@nedelko.cz](mailto:info@nedelko.cz)  
W [www.nedelko.cz](http://www.nedelko.cz)

#### NEDELKO GERMANY GMBH

Heinz-Bäcker-Str. 27  
45356 Essen  
T +49 (0)201 560503 50  
E [info@nedelko.de](mailto:info@nedelko.de)  
W [www.nedelko.de](http://www.nedelko.de)